

DO NOT SCALE DRAWINGS  
 CHECK AND VERIFY ALL DIMENSIONS BEFORE  
 PROCEEDING WITH THE WORK.  
 DRAWINGS NOT TO BE USED FOR CONSTRUCTION  
 UNLESS STAMPED AND SIGNED BY THE CONSULTANT.  
 THESE DRAWINGS HAVE BEEN DESIGNED IN  
 CONFORMANCE WITH THE ONTARIO BUILDING CODE.

Revisions and Issues

REV.	DATE	DESCRIPTION
1	2019/09/04	ISSUED FOR REVIEW
2	2019/09/09	ISSUED FOR REVIEW
3	2019/11/12	ISSUED FOR REVIEW

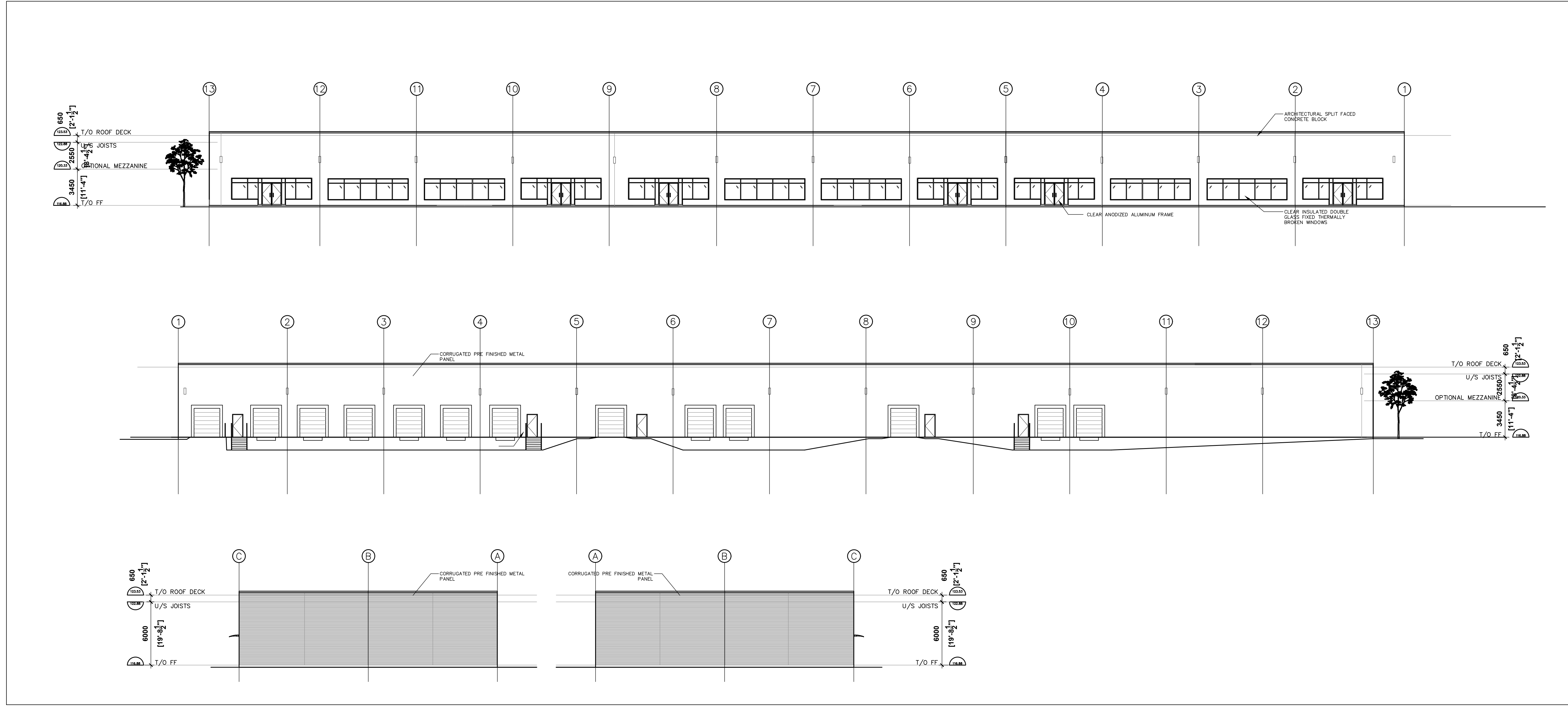

1 ELEVATIONS  
 A300 SCALE: 1:200

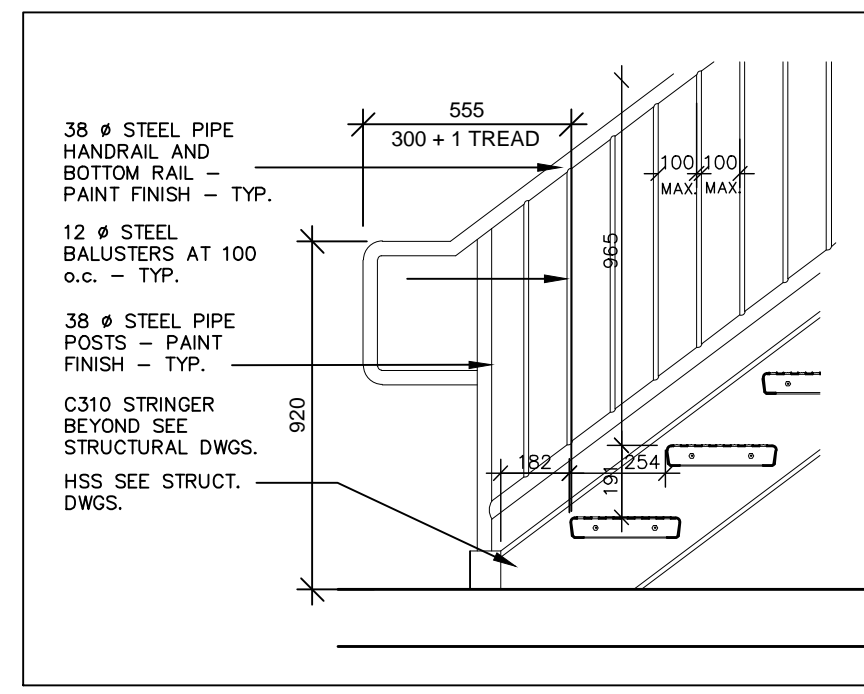

2 STAIR DETAIL  
 A300 SCALE: 1:20

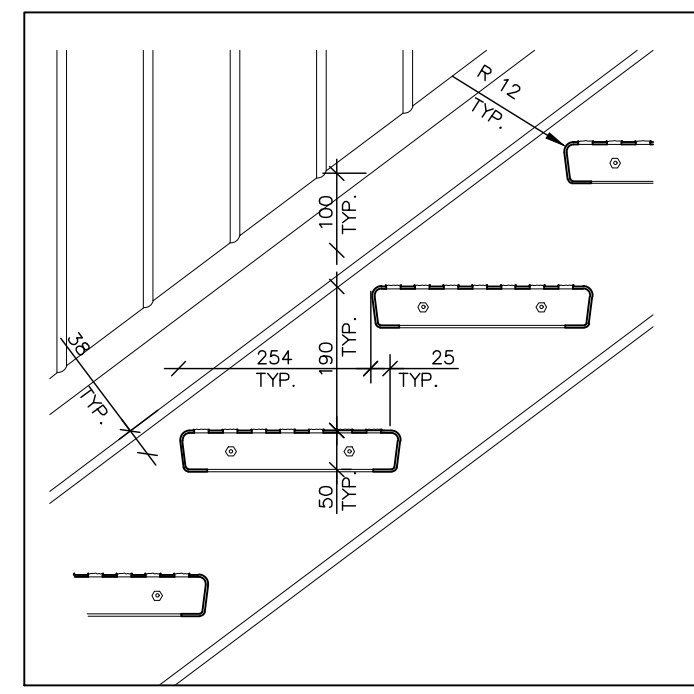

3 STAIR DETAIL  
 A300 SCALE: 1:10

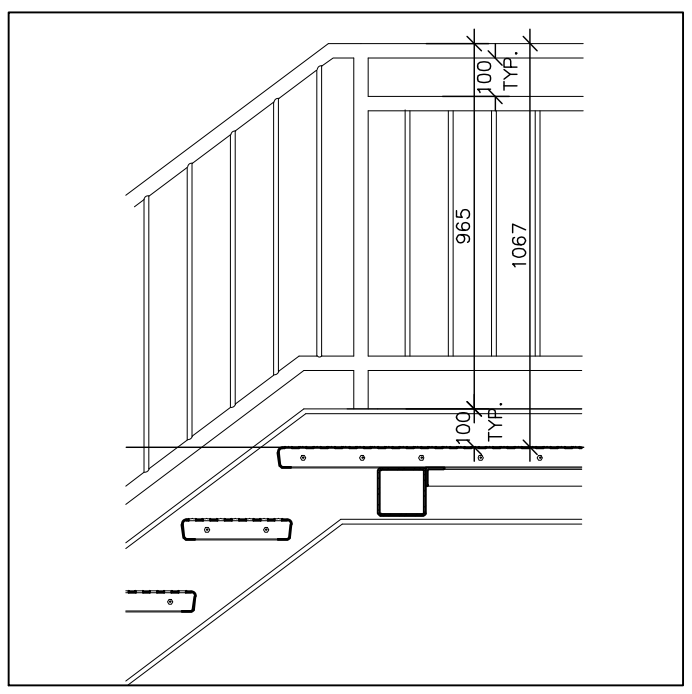

4 STAIR DETAIL  
 A300 SCALE: 1:20

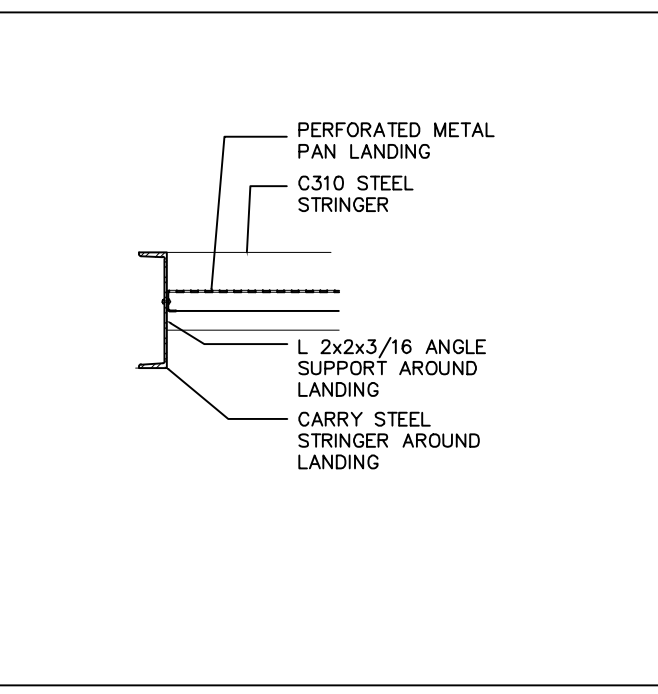

5 STAIR DETAIL  
 A300 SCALE: 1:20

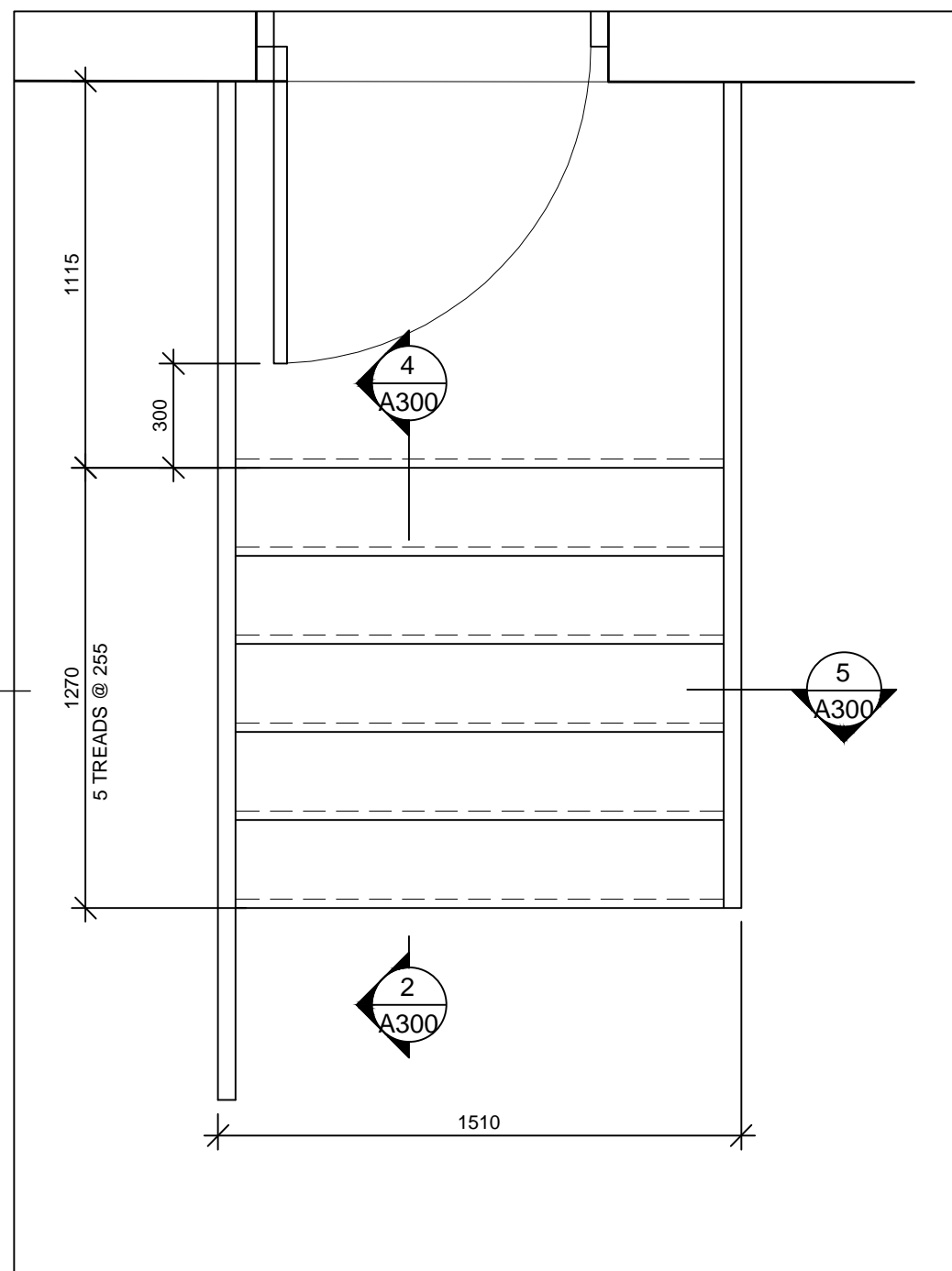

6 STAIR PLAN  
 A300 SCALE: 1:20

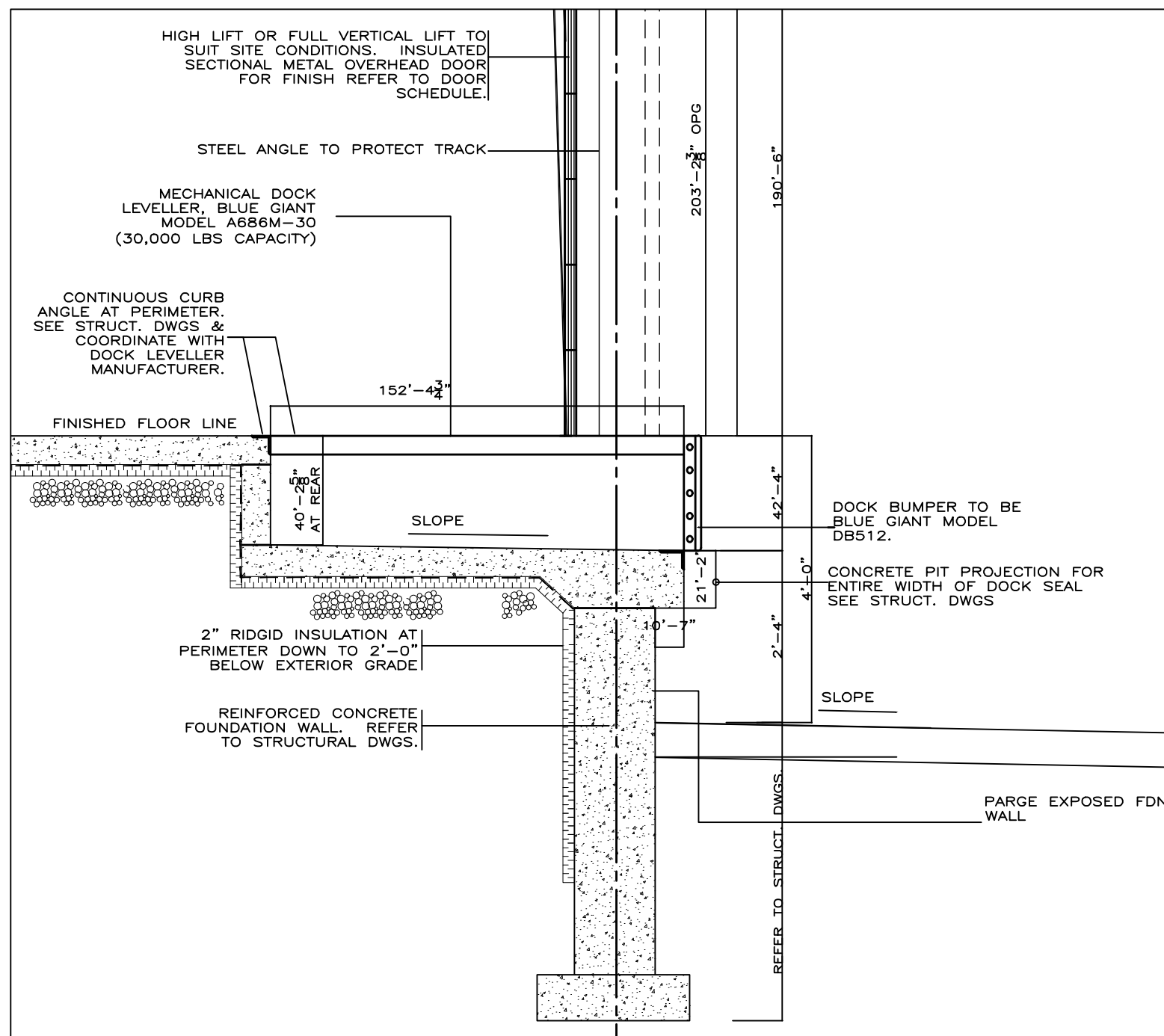

7 DOCK LEVELER DETAIL  
 A300 SCALE: 1:25

**Alexander Wilson Architect Inc**  
 Admiralty Place  
 103-20 Gore Street  
 Kingston, ON K7L 2L1  
 T: 613-545-3744  
 F: 613-545-1411



Project  
**PROPOSED NEW WAREHOUSE DEVELOPMENT**  
 37 BLESSINGTON ROAD  
 BELLEVILLE ONTARIO

Drawn By: MH  
 Checked By:  
 Scale: Date:  
 Project No.: 2005  
 Revision: 1  
 Drawing No.:  
**ELEVATIONS**  
 APRIL 2020  
 A300  
 1:1