

# MEMORANDUM

Ainley Graham & Associates Limited  
139 Front Street Unit 100, Belleville, ON K8N 2Y6  
Tel: (613) 966-4243 P Fax: (613) 966-1168

---

**To:** Greg Pinchin **Copy to:** File  
**From:** Caitlin Sheahan  
**Date:** June 3, 2020  
**Ref:** County Transport Site Plan Application and Zoning By-Law **File:** 20525-1  
Amendment – Servicing Review

---

## Comments:

County Transport (2706684 Ontario Inc.) is proposing a Zoning By-Law Amendment and Site Plan Application for their property located immediately east of Highway 37 and south of Blessington Road (**Figure 1**). The development property is 10.0 hectares (ha) in size; it is currently zoned for agricultural use but is proposed to be rezoned to allow light industrial use. It is proposed to develop the land with three warehouse buildings, eight self-storage buildings, parking areas and laneways to create a truck terminal with associated warehousing (**Figure 2**). The purpose of this memo is to provide a review of the proposed site plan with regard to future servicing.

The subject property is outside of the City's servicing boundary for Municipal watermain and sanitary sewer. The subject property will therefore be serviced by an on-site sewage system and well.

As the proposed use of the site includes warehousing and self-storage, there will be few employees and minimal water usage and flows to the septic system. As part of our preliminary design work, we have physically examined the site and reviewed the Ontario Building Code requirements. Subject to the normal process of Site Plan Review, given the large size of the subject lands, it is anticipated that the development can be serviced adequately by an on-site sewage system.

With regard to the provision of water, an on-site well will be installed according to all application regulations to provide potable water. However, since Municipal watermain is not available to the site, it will be necessary to have on-site water storage for fire-fighting purposes.

Based on a calculation from Ontario Building Code Appendix A-3.2.5.7.(3)(c.) and the size of each warehouse, 71,000 gallons will need to be stored on-site based on a minimum flow rate

of 9,000 L/minute for 30 minutes (for this calculation it was assumed that only one warehouse would be on fire). It is proposed to provide the on-site water storage using four tanks: three 20,000 gallon Norwesco N-43825 vertical tanks (4.19m diameter) and one 11,000 gallon Norwesco N-44013 vertical tank (3.66m diameter). Specification sheets for these tanks are enclosed. The tanks will be connected to an on-site dry hydrant for fire-fighting.

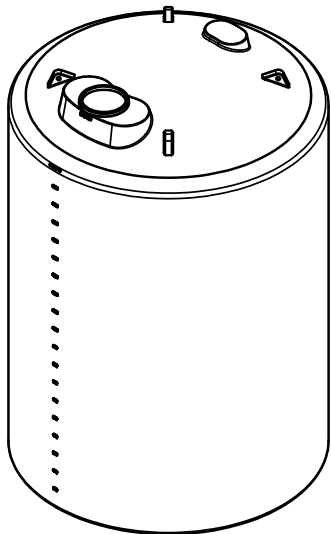
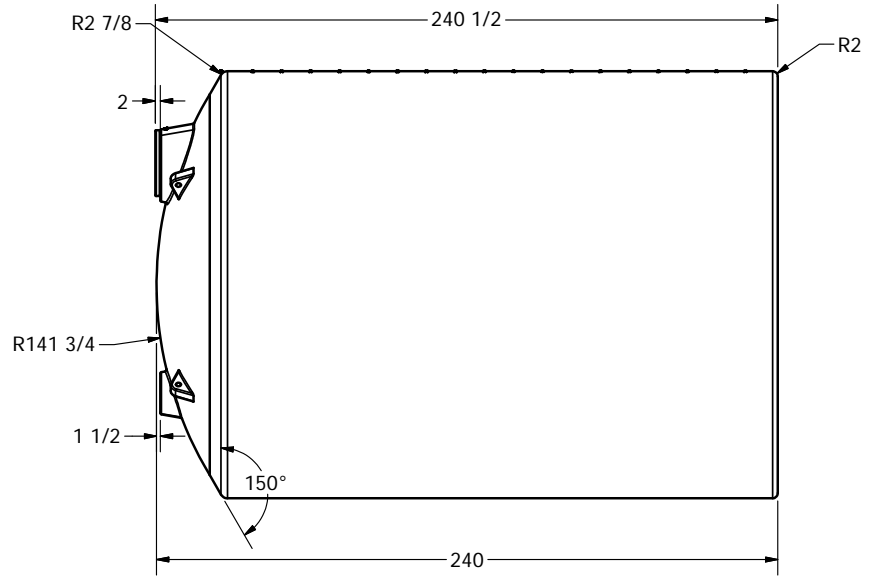
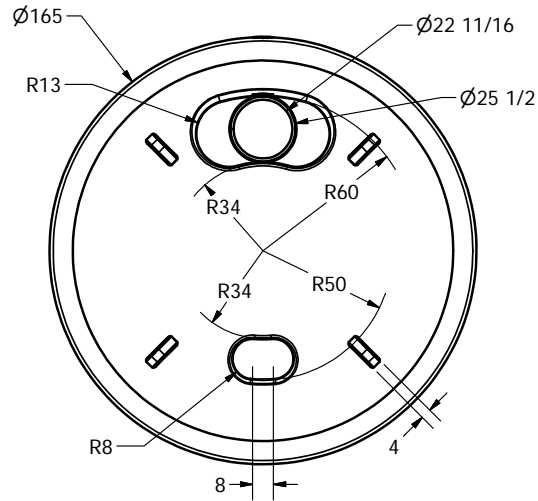

DRAWN Jerry Paulson	10/12/2010	 <b>NORWESCO</b>		
CHECKED		NORWESCO, INC., ST. BONIFACIUS, MN		
QA		TITLE		
MFG		20,000 GALLON VERTICAL TANK X 165 DIAMETER		
APPROVED		SIZE	DWG NO	REV
		B		
		SCALE: 1/48	SHEET 1 OF 2	

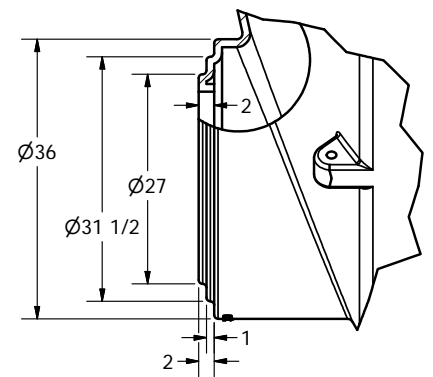
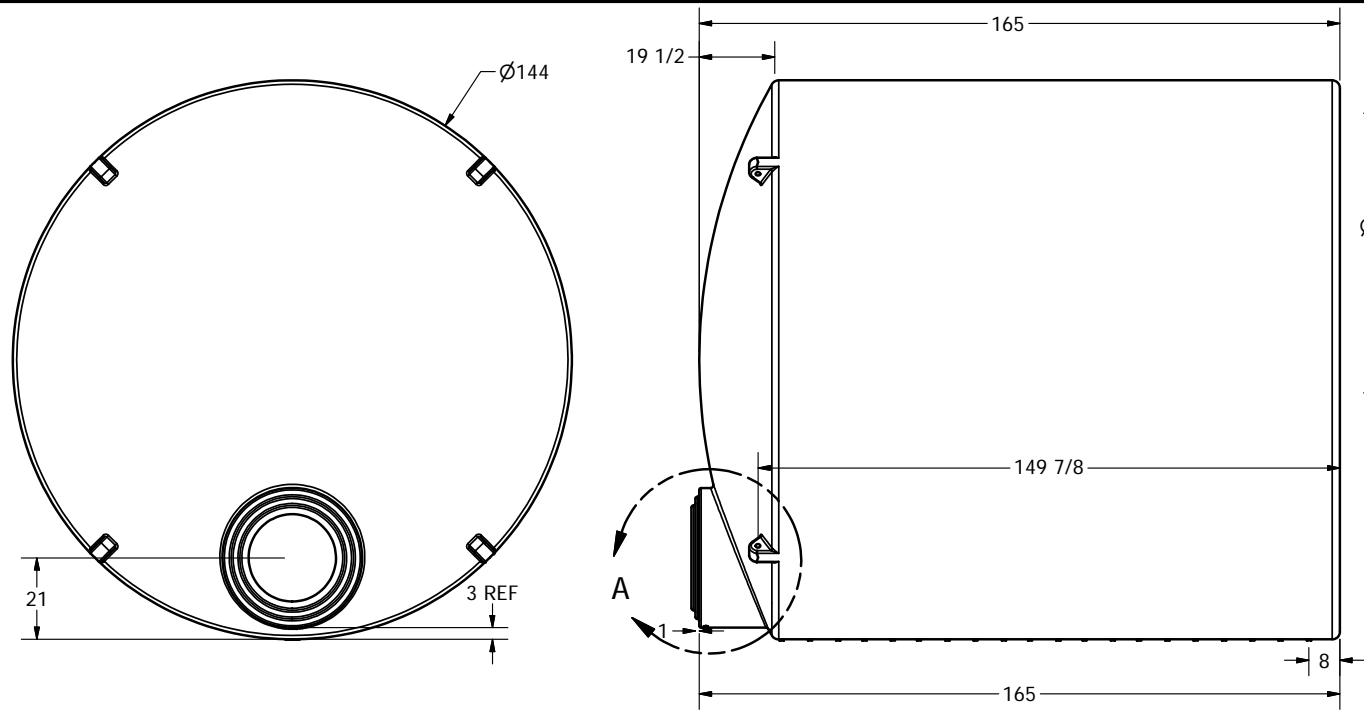

DETAIL A  
SCALE 1 / 16

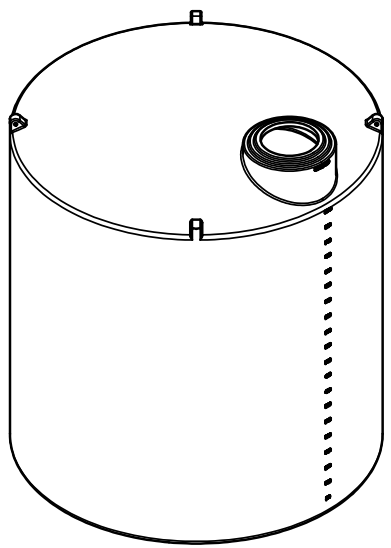
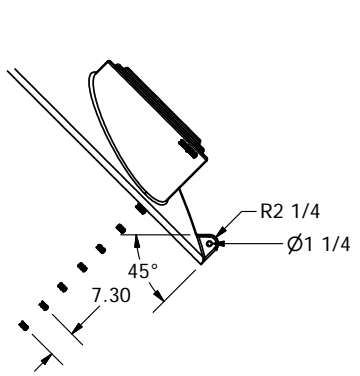

DRAWN Jerry Paulson	4/6/2012			
CHECKED		NORWESCO, INC. SAINT BONIFACIUS, MN		
QA		TITLE		
MFG		11,000 GALLON VERTICAL TANK X 144 DIAMETER		
APPROVED				
		SIZE B	DWG NO	REV
		SCALE: 1/32		SHEET 1 OF 1